

## COMPACT SOLID STATE HIGH VOLTAGE SUPPLY\*

E. M. SHEEN

*Nucleonic Instrumentation, Instrument Research and Development, Physics and Instruments Laboratory, Hanford Laboratories and*

*C. A. RATCLIFFE*

*General Electric Company, Richland, Washington*

Received 11 May 1964

A compact, electronically-regulated, solid state high voltage supply was developed for use in scintillation spectrometry applications. Miniature transformers were used to minimize the

weight and a voltage range from 600 to 1500 V d.c. at 0.25 mA is provided with a voltage temperature coefficient of 0.01% better.

### 1. Introduction

Scintillation gamma spectrometers require high voltage power supplies of exceptional stability, low temperature coefficient and low noise output. In addition, the design of compact portable spectrometers requires the high voltage supply to be small, light weight and to be capable of moderate current output at stable and adjustable voltages. A high voltage supply meeting these general requirements was developed using solid state components and miniature transformers.

\* Work performed under Contract AT(45-1)-1350 between the Atomic Energy Commission and the General Electric Company.

### 2. Discussion

A compact solid state high voltage supply, which is shown schematically in fig. 1, was developed for use in experimental battery-powered and compact line-powered gamma spectrometer instruments.

A small meter is employed to indicate the approximate high voltage magnitude and a ten-turn potentiometer is provided for adjustment of the voltage in sufficiently small increments to permit use of the one control for gain of the gamma spectrometer instrument.

The circuit diagram for the supply is shown in fig. 1. The circuit is not complex and comprises an oscillator-amplifier, miniature transformers, rectifier, filter,

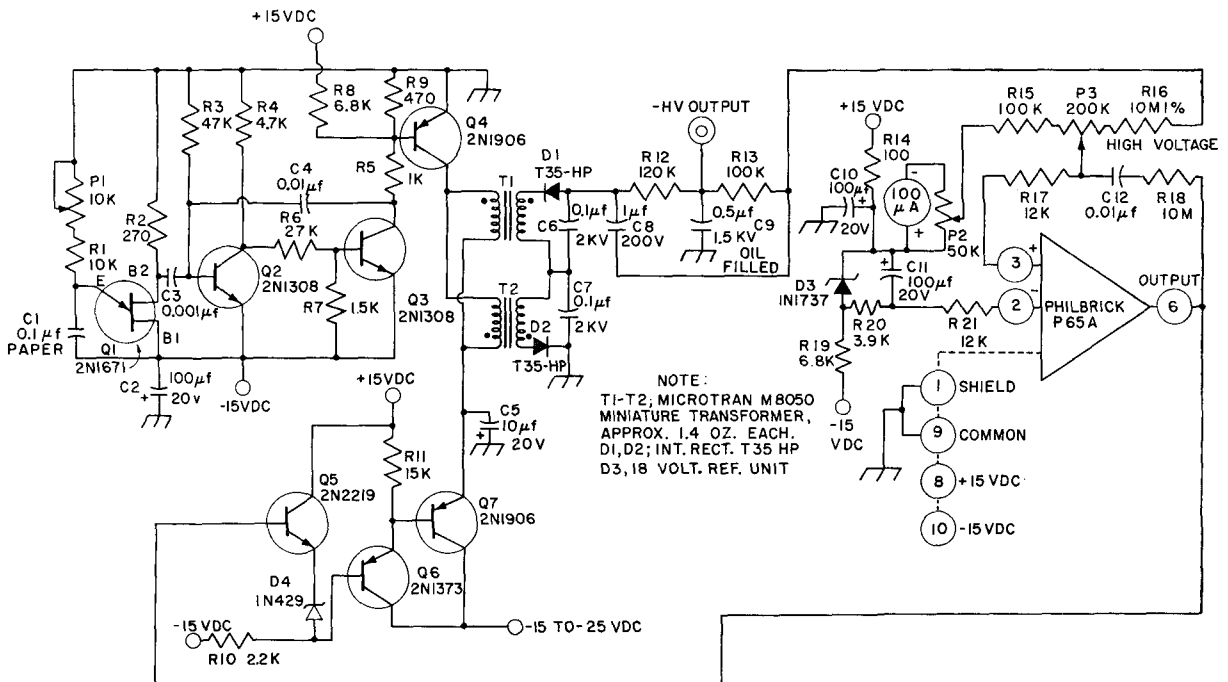

Fig. 1. Circuit diagram.

voltage reference unit and an operational amplifier. The operational amplifier compares a sample of the high voltage with the reference unit voltage and drives output emitter followers. The power emitter follower output sets the voltage amplitude from the oscillator-amplifier to provide the required power at high voltage from the rectifier-filter combination.

A Unijunction\* transistor oscillator, Q1, is used to provide an adjustable frequency pulse source to trigger a fixed pulse width monostable multivibrator, Q2 and Q3. Potentiometer P1 is used to adjust the frequency for maximum efficiency. Circuit power required is +15 V d.c. at 10 mA, -15 V d.c. at 17 mA, and an unregulated source of -15 to -25 V d.c. at 30 to 60 mA depending on high voltage output load. The monostable multivibrator output is direct-coupled to a power transistor switch, Q4, that connects two miniature transformers across a voltage level set by another power transistor, Q7, which is controlled by the operational amplifier output voltage.

High voltage pulses from the two transformers are rectified by small selenium stacks and the charge is stored on capacitors C6 and C7. Resistor R12 and C9 filter the output voltage and R13 decouples the d.c.

\* Registered General Electric Company trade name.

sample line from C9. Capacitor C8 provides an a.c. signal to the sample line to prevent C9 from causing instability. A fraction of the high voltage is connected to the positive input of the operational amplifier through R13, R15, R16 and P3 and is adjusted by the setting of P3. The negative input of the operational amplifier is connected to D3, an 18.6 V d.c. reference diode. The difference voltage is amplified by the operational amplifier and the output voltage is applied to the base of emitter follower Q5. A Zener diode is used to offset the emitter follower voltage toward B- by 5 V d.c. Additional current gain is provided by Q6 and Q7 to set the voltage across C5 and the transformers.

### 3. Results and conclusions

Power supply prototypes were fabricated from the circuit of fig. 1 to provide from -600 to -1500 V d.c. output at load currents up to 0.25 mA. The temperature coefficient at 1000 V d.c. was  $0.007\%/^{\circ}\text{C}$ ; this variation was approximately equal to the voltage variation with temperature of the particular reference diode used for the test. The ripple voltage measured was 10 mV, peak-to-peak. The supply promises to be useful for both portable battery-powered and line-powered scintillation spectrometer applications.